

JY210E

Crawler Hydraulic Excavator

RANGER



FEATURES

- Fitted with Cummins engines
- Excellent matching between engine and hydraulic system to prolong components life span
- Highly efficient and energy saving with its advanced electronic monitoring control system
- Hydraulic power steering and slew system offers turning, rotational and working stability
- Ergonomically designed air-conditioned operator's cabin
- Suitable for a wide range of applications such as general excavation, building, road and municipal construction work

SPECIFICATIONS

Item	Performance
Vehicle Mass (t)	21
Standard bucket capacity (m3)	0.9
Diesel engine	Cummins
Model	6BT5.9-C
Power (kW)	105
Hydraulic system	Interlacing capacity control, negative flow control
Flow (L/min)	2 x 200
Pressure (Mpa)	30
Travel speed (km/h)	3-5
Grade climbing capability (%)	60
Slew velocity (r/min)	13
Bucket digging force (kN)	135
Scoop digging force (kN)	100

JY210E

Crawler Hydraulic Excavator

RANGER

DIMENSIONS

A	Total length	9500 mm
B	Total height (to boom top)	3150 mm
C	Total width	2840 mm
D	Total height (to operator's cab top)	2770 mm
E	Ground clearance (bob-weight)	1030 mm
F	Minimum ground clearance	454 mm
G	Stern swing radius	2855 mm
H	Length of track on ground	3400 mm
I	Length of track	4200 mm
J	Track gauge	2200 mm
K	Width of track shoe	600 mm
L	Height of hood	2260 mm
M	Width of hood	2195 mm

OPERATING SCOPE

A	Maximum digging height	9000 mm
B	Maximum dumping height	6300 mm
C	Maximum digging depth	6700 mm
D	Maximum digging radius	9910 mm

DIMENSIONS

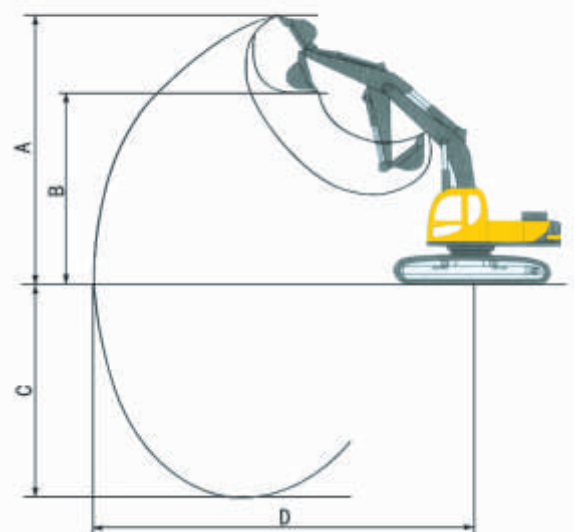
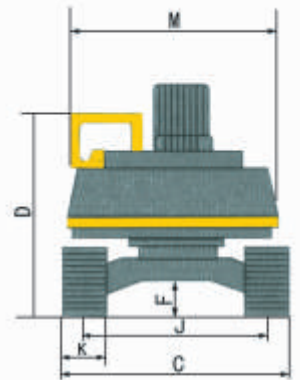
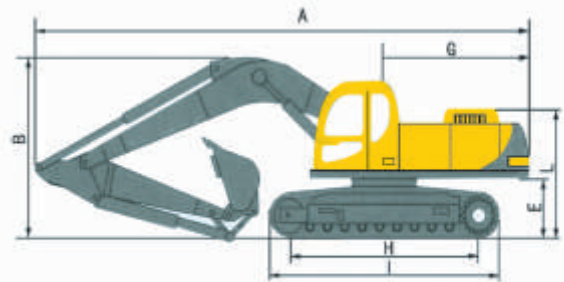

RANGER

22 Shettleston Street
Rocklea
Queensland 4106

Ph: 07 3275 1166

Fax: 07 3274 3919

Email: sales@ranger-loaders.com

Note: Specifications are subject to changes by the manufacturer without prior notice. Images for illustration purposes only.